



Norton Notice



The Newsletter of The Northern California Branch

VOLUME 3 ISSUE 4

APRIL 1980

FOR HARD WEAR

Holder of 7 WORLD'S RECORDS,
1 mile at 73½ m.p.h. to 150 miles at
64 m.p.h., and winner of innumerable
trials—speed, reliability, hill-climbing,
flexibility—in all parts of the world.

THE LONG STROKE NORTON with the
long, low frame, undoubtedly set the fashion in
the motorcycle world. Of scientific design, neat
appearance and wonderful capacity power, it has
"created a remarkable following," and shows great
foresight and grasp of the essential on the part of
its designer." —*Press*

"The Unapproachable"



General Specification.

Transmission—Big four 1 in. belt, 2½ h. p. 1 in. belt. Lyco.

The Tank is of alerl, the bottom and sides being formed of
one seamless piece (avoiding the bottom joint which are so
frequently a source of leakage), heavily treated, aluminium, and
lined in black and red. The fuel station contains the tubular
oil compartment with internal pump just forward of the saddle,
so avoiding the long reach and inconvenient working position
generally necessary when lubricating, and being sheltered, obvi-
ates difficulties caused by frozen oil. Capacity—Petrol 1½ gall.,
Oil ½ gall.

Large Filters are fitted, enabling the quantity of petrol to
be seen at a glance, and the tank to be quickly filled.

Lubrication is by a Tapless pump, through large diameter
tubes.

Frame—is of extremely neat appearance; it gives a very low
seat enabling a rider of average height when in the saddle to
place both feet firmly upon the ground. The height from ground to
top of seat tube is 25½ in.

"BIG FOUR" (82 x 120) 636 c.c.
For hard pulling, with Sidecar.

3½ h.p. (79 x 100) 490 c.c. FULL
TOURING.

NORTON "T.T." 490 c.c. RECORD
TYPE.

2½ h.p. (70 x 90) 346 c.c.

The NORTON MANUFACTURING CO. LTD.
"The Works,"
Birmingham Road North, BIRMINGHAM, ENGLAND.

Footboards—Are of aluminium and of good length with
curved up front, very comfortable.

Tyres—2½ in. Clinchers.

Brakes—Norton new non-lock Vee brake, very powerful but
level on action, and front non brake.

The Stand—Is of entirely new design, made of stiff tube,
aval action and spring operated.

Spring Forks—Special design Norton Deird of graduated
width, from wide centre to crown to narrower head and
heel, giving great lateral strength to resist sideway strains.

Saddle—Lyco large, padded pan seat.

Gear—Mark VI, three speed Armstrong, direct
top drive. Gears of 5.74 and 11, or stated by
a Norton adjustable pulley. Handle or kick
starter.

THE NORTON NEVER BREAKS VALVES.

The Norton Engine of 79 x 100 mm. bore and
stroke — 490 c.c. capacity,
has too well demonstrated its superiority in design and efficiency to
require mention of further proof in so condensed a list. It must suffice
to say that the projected features of design, piston and piston rings,
with their compression and oil retaining channels are used. The valves
are of nickel steel, and 18 in. diameter, and we have yet to record the
first breakage of a standard valve head.

Copyright © NORTON, BIRMINGHAM.

Oh! But for the use of a time machine with a motorcycle trailer.

Published monthly by the
Northern California Branch
Norton Owners Club





Published monthly by the Northern California Branch, Norton Owners Club

BRANCH OFFICERS

PRESIDENT

Steve Coburn
P.O. Box 236
La Honda, CA 94020
(415)747-0326 Home
(415)497-6601 Work

SECRETARY/TREASURER

Carolyn Scott
1970 Latham #14
Mountain View, CA 94040
(415)968-5117

NORTON NOTICE STAFF

Michael Heth
87 Ord St., Apt. 3
San Francisco, CA 94114

Meda Rago
Copy Ed., Typist,
Proofreader

Dick Swanson
Special Technical Projects

Brian Halton
Special Projects

Club business is best handled through the mail--especially material of any sort for the Club Newsletter. Use the above addresses.

BRANCH MEETINGS

Generally held the second Thursday of each month at a location announced in the NOTICE.

BRANCH RIDES

Rides are generally held the following Sunday at 10:00 am at a location announced in the NOTICE. In the event of rain the ride will be postponed 1 week. Occasionally, rides are on a Saturday or over the whole weekend. Check the NOTICE Calendar each month.

ODD RODDINGS (Reprinted with permission)



There are three categories of membership in the Northern California Branch of the N.O.C.:

FULL MEMBERS: Full members are dues-paying members of the N.O.C., and therefore have full voting privileges at any general meeting of the N.O.C. and all branch meetings, and also any privileges resulting from affiliation of the Club with any other organization. Full members must pay annual dues to the N.O.C. in England (paid through the Secretary), in return for which they will receive the bi-monthly ROADHOLDER magazine and may use the N.O.C. Spares Scheme at any time.

ASSOCIATE MEMBERS: This category was set up so that any Norton owner wishing to get the NORTON NOTICE each month and be associated with the Northern California Branch can do so for a very modest fee, without having to join the N.O.C. as a full member. Associate members do not pay N.O.C. dues, and therefore do not have all the privileges of full N.O.C. members. They do, however, have full voting privileges at all Northern California Branch meetings and are equally welcome at all of the rides, meetings, and other functions sponsored by the branch.

SOCIAL MEMBERS: In order to allow Norton enthusiasts who do not own a Norton to be associated with the Club and thereby help them to find one to buy, the branch provides the category of 'Social Membership'. Social members do not have any voting privileges but are otherwise welcome to participate in all branch activities. Social members will receive the NORTON NOTICE each month and are encouraged to follow up on any leads regarding Norton motorcycles for sale. The Editor will try to help all social members in this regard and would appreciate any help from other members.

CURRENT DUES PAID AND PUBLICATIONS

	<u>RECEIVED</u>	
	<u>PAY</u>	<u>RECEIVE</u>
<u>FULL MEMBERS</u>	\$25	<u>NORTON NOTICE & ROADHOLDER</u>
<u>ASSOC. MEMBERS</u>	\$10	<u>NORTON NOTICE</u>
<u>SOCIAL MEMBERS</u>	\$10	<u>NORTON NOTICE</u>

THE EXHAUST NOTE



Last month's NOTICE included the Rally in the Redwoods notice which caused the scales to tip over 1 oz. I didn't know that, and it seems that a few of the clowns in the postal service actually weighed them and nicked some of you the additional postage. Sorry. Which brings up a point -- the phone number listed at the lower left hand side is wrong. It should be 925-6425, not 5425.

The weekend of March 23 was beautiful, and many members found their way up to the Classics Races at Sears Point. I rode up with Tom and Adrienne Skillington. We met Dennis Magri and Claude Wright enjoying the activities, whilst fending off sunstroke with plenty of brew. We saw one Norton finish 2nd in a race, and there were plenty around. It was a real gas with all of the unusual bikes and cars. There's another meet in November at Laguna Seca, and I think a Club pit area for real motorcycles might be interesting. Just a place where all the Norton nuts could congregate and admire the machines. I'm thinking of trying to get this together; if it sounds interesting to you, let me know. If you missed this event, check out the calendar next month and set the day aside.

I forgot to re-mention it last month, but the Norton Profile of Bob Bausch was done by Brian Halton. He's working on another, so "watch out". He may profile you next. Better polish up the old Nort tonight.

Please be sure to mention that you saw their ad and are a member of the NOC every time you patronize one of our advertisers. Some don't know if their ad is worthwhile, while we, of course, all do.

Also -- be sure to check your NOTICE envelope each month for any notes etc from the Club. We put these in a few days before the NOTICE, and there's no indication that they're in there. You just have to look.

See you at the London House,

MM



<u>DATE</u>	<u>TIME</u>	<u>PLACE</u>	<u>EVENT</u>
4-10-80	7:30PM	London Hse Palo Alto	Branch Meeting
4-13-80	10AM	Alice's Restrnt	Branch Ride

AS USUAL - ONE LAST THING.
I'VE LOST THE CARD FROM
THE LONDON HOUSE AND I'M 5
MINUTES FROM THE PRINTER. IT'S
ON 630 RAMONA OFF UNIVERSITY,
OFF 101. TAKE A LEFT OFF
UNIVERSITY. IT'S IN DOWNTOWN!
PALO ALTO. NOW THAT YOU KNOW
THAT YOU'VE GOT TO COME.
THIS WAS GOING TO BE ONE
OF MY FAMOUS EMPTY SPACES
AGAIN SO IT'S JUST AS WELL
I LOST THE CARD.

MM

KEEP ON NORT'N!

Well, my hope last month for some nice riding weather was evidently heard by someone above. Those of you who made it to San José for the March ride were rewarded by beautiful spring weather and a most enjoyable ride up to the Mount Madonna Inn, where we stopped for a rather slow and expensive lunch, and then a tremendous afternoon of riding through the Santa Cruz mountains. Although efforts were made along the way to follow the map, we did manage to take a number of wrong turns as we worked our way north from Watsonville to Hwy. 35 (Skyline Blvd.). The southern portion of Summit Road is now closed to through traffic (by a locked gate), and we had to double back and take an alternate route. Nevertheless, it was beautiful riding all the way, and it really seemed as though someone upstairs likes Norton motorcycles too! Those of you who didn't come missed a good one. Hope to see you next time.

The March meeting at Edinburgh Castle was a lot of fun too, and it marked the advent of what I hope will become a regular feature at our Branch meetings. Jan Barton, our resident Manx nut, came prepared to demonstrate many of the finer points of the Manx motor. And I do mean PREPARED! Jan brought a complete Manx 500 motor, which kept him up until 3 AM the night before in preparation for the presentation he gave us at the meeting. For those of us whose knowledge of Norton motors is rather limited, it was quite an educational experience, and I believe everyone present thoroughly enjoyed the show. I'd like to extend a special thanks to Jan, on behalf of the Branch, for working so hard to provide this special tech. session. I also want to encourage anyone else out there who might be interested in doing a similar presentation at a future meeting, to speak up. We really can use more of this sort of thing, and your mechanical whizzes can make a big contribution to the Club by doing one of these sessions at a Branch meeting. Please contact me if you would be interested, and we'll set it up.

In other business the CAMA Rally, scheduled for May 3-4, was discussed, and the following are my conclusions. Firstly, it doesn't seem that many bay area members are interested in riding down to Lancaster for this year's rally. I am planning to go, however, and would like to hear from anyone else in the area who wants to join me for the ride down. Secondly, I doubt that we will need the twenty rooms I had tentatively reserved at the Essex House in Lancaster for a Norton group, but I will be sending down my own deposit for a room, and would be glad to do the same for anyone else in the Club. If you would prefer to do it yourself, the phone number of the Essex House is (805)948-0961. Call them and say you'll be with the Norton group, and they will hopefully give us all one block of rooms.

I want to encourage all members to remember to pay Club dues on time (or sooner if possible). We are operating on a small budget and really need your help to maintain a healthy cash flow and remain solvent. Likewise, all advertisers are requested to send their checks to Michael Heth when contacted. This is very important!

I look forward to seeing many of you at this month's meeting in Palo Alto (London House on Thursday, April 10 - 7:30 PM). *Steve*

CLUB EVENTS CALENDAR

DATE	TIME	PLACE	EVENT
4-10-80	7:30PM	London Hse Palo Alto	Branch Meeting
4-13-80	10AM	Alice's Rstrnt	Branch Ride
Planned route: Skyline, down Tunitas Creek Rd, south on Hwy 1 to Pescadero Rd. Lunch at Duarte's in Pescadero at noon. After lunch we'll ride up Alpine Rd to Skyline and then down Page Mill Rd to the Alpine Beer Garden (Rosotti's) in Portola Valley for a nice, cold beer.			
4-26,27		Ontario Motor Speedwy	Vintage Racing
5-3 & 4		Lancaster CA	CAMA Rally
6-15-80			Beer Bust
No known race conflicts. Flier will be sent in May <u>NOTICE</u> .			
7-13-80		Sears Pt. CA	AMA Road Race
Possible Club Ride. Meet in Sausalito at 10AM.			

Anyone interested in organizing the Annual Norton Beer Bust? Please step forward. The work isn't much. You'll mostly have to arrange the location and the beer.

BACK ISSUES AVAILABLE

Write: Steve Coburn
P.O. Box 236
La Honda, Ca 94020

ROADHOLDER \$3 each

No. 80 - July/August, 1978 (1 only)
No. 82 - Nov/Dec/Jan, 1978-79 (six)
No. 83 - February, 1979 (seven)
No. 84 - March/April, 1979 (1 only)
No. 86 - July/August 1979 (1 only)

NORTON NOTICE 50¢ each Xeroxed only

Vol 1 - Issue 1 - April, 1978
Issue 2 - May, 1978
Issue 6 - Sept, 1978
Issue 9 - Dec, 1978
Vol 2 - Issue 2 - Feb, 1979
Issue 3 - March, 1979

All other issues available in varying quantities.

Stamped, self-addressed envelope must be included with all back-issue orders.

LETTERS

My Highly Esteemed Editors,

The written word finally issues forth from an heretofore totally inactive member. Inactive, that is, in the Club. Keeping a Norton rolling in the dead of winter at 6350 ft. not only requires lots of energy expenditure but is really very foolish.

You see, where there is no snow on the road, there is mostly a lot of sand, and even occasionally some salt.

I relate these words to be taken by the wise or gullible along with a few high altitude tuning tips.

Above sea level, it is desirable to advance the spark timing by $1\frac{1}{2}^\circ$ per 2,000 ft of elevation. Subsequent to calculating my advancing needs to be exactly 4.85", I gave my points a little nudge which begot two results: Great fear for my new pistons and the immediate reclamation of most of the power sacrificed to the gods of the High Sierras.

After setting my needles a notch lower (the top groove), I have been satisfied enough with the running of my Beast to have neglected any attempt to re-jet. This is not to say that experimentation in this area would not produce beneficial results but is merely a reflection of my lazy, vain, carelessly indifferent self.

I am told by long-time mountain dwellers (easily identified by their never-varying costume of flannel shirts and stovepipe Levis) that the use of Premium at these altitudes is unnecessary, and I have found that to be true. I use Premium anyway.

One more modification I have found to be most helpful (though having nothing to do with altitude): Long ago I confronted the problem of the exhaust pipe retaining collars vibrating their gaskets flat, coming loose, evading those dumb "lock rings" that fold into the heat sink fingers, and threatening total disengagement from my cylinder head... on the Benicia Bridge (read: "No Stopping"). Judging from that experience, I concluded that the use of boot pressure or those dumb lock tabs were altogether inconvenient. I set about devising a simple, effective means of retention. Being chronically negligent by nature, I knew my means must also be maintenance-free.

Norton

SPOKEN HERE

We stock a complete line of genuine Norton parts. Write for our accessory catalogue. 10% discount to members. VISA/Mastercharge accepted.

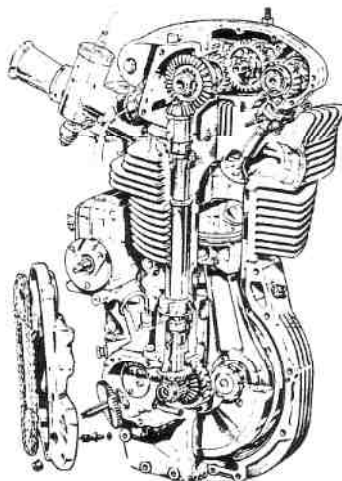

BRIAN SLARK CLASSIC MOTORCYCLES

785 B West 17th Street
Costa Mesa, CA 92627
(714) 642-8411



PALO ALTO YAMAHA

YAMAHA • TRIUMPH • NORTON

SALES • SERVICE • PARTS

3960 EL CAMINO
PALO ALTO, CA. 94306
415 493-3414

Norton PARTS AND SERVICE

GARY BROEDER: EXPERT MECHANIC
N.O.C. MEMBER

Although not emphasizing British bikes on the salesroom floor, PALO ALTO YAMAHA has one of the bay area's best British motorcycle mechanics back in the shop. Gary Broeder knows as much as anyone in the area when it comes to making NORTONS run right. With his racing experience, Gary can work wonders on your machine when it needs help. I highly recommend PALO ALTO YAMAHA the next time you need a good mechanic for the old NORTON.

In time, as by sudden divine gift, the image of a 2-stroke type pipe retaining spring sprang into my yawning mental abyss. I saw holes, drilled into all those little heat dissipating fingers to provide adjustment, and a single hole through a cylinder head fin to provide anchorage. As if in a dream, I secured possession of my visionary springs, then proceeded to drill holes through my beloved Norton. After crushing my nose with my thumb knuckle when my insufficiently gripping pliers lost their precarious grasp on the muscle-y little springs, I slowly awoke to the need of everyman's favorite tool, the vice grips! Voila! My pipes have never since come loose in 5 years of riding.

Yours in sincerity, goggles, and gloves,

Ed Louchard
Lake Tahoe, CA

Dear Mike,

I just received my NORTON NOTICE and was really knocked out by that fantastic song on page 5, "Talkin' Norton" by Art Sirota. It was easily the high point of this month's NOTICE and equal in funniness to four and a half "Odd Bodkins". Tell that songwriter to keep up the good work. We need more of these witty, insightful, and modest comments in poetry. Just one question: Who is Brian Slark?

Your friend,
Art Sirota

March 27, 1980

Dear Steve,

This is Paul Garson speaking to you from the basement of Brentwood Savings and Loan...but I won't be here much longer. The Norton gods have smiled upon me, and I've joined the staff of Touring Bike, Big Bike, and Chopper magazines as an editor. It promises to be very busy but interesting work. Word is out to the publisher that I'm a Nortonophile, and I hope to do all I can for the marque, and for all of us so afflicted, addicted or blessed.

Let it be trumpeted about the Norton countryside, far and wide, that I am interested in seeing lots of Norton photos, preferably black and whites, and leads for articles, especially events or special bikes. I hope to be the official rep of the magazines at the 1980 Rally and would appreciate any advance data (and scoops, such as an article on a live Wankel Norton) that could be directed my way.

My crashed Fastback is back on the road, although a tad quiltwork, but another Norton is incubating, hopefully soon to be giving supportive care to its ailing brother.

AIRCRAFT TYPE BRAKE HOSE KITS



BOLT ON

Brilliant Appearance
Maximum Performance
Unsurpassed Reliability

EASILY INSTALLED

Direct Replacement
Stainless Reinforced Teflon®
Competition Brake Hose Kits
for All Brands of Disc Brakes

10% discount to NOC members
Catalog \$100, refundable 1st order



Co-Sponsor of Mark Ingalls' Norton 850,
winner of the AFM 200 mile endurance
road race, Nov. 18, 1979, Sears Point.

AERO CYCLE SYSTEMS

P.O. Box 635
Lafayette, California 94549 U.S.A.
Phone (415) 671-2851

* Teflon is Du Pont's trademark for TFE fluorocarbon resins

I'd like to keep an open line to the Norton family, so feel free to get in touch with me at any time. I'm posting a copy of this letter to the NOTICE.

P.S. On the newstands this month, three of my stories are in print. The mags are Gallery (don't look at the pictures!), Iron Horse, and Chopper.

P.P.S. I could use a good seat for my fastback.

Hope to see you soon. Good riding!

Paul Garson
c/o Touring Bike
Publishing
4247 E. LaPalm Ave.
Anaheim, CA 92807

This is the letter I received. It looks like we have a friend on the inside now. Give him the Norton support he needs.

nm

Uncle Joseph's Nightly Prayer
(To be recited whilst genuflecting)

Now I lay me down to rest
knowing Lucas electric's are best
the tail and headlight shine so
bright
I pray someday they'll work at
night

Through crowded streets and roads
that wind
mid drivers who are deaf and blind
my trusty horn commands respect
and keeps my bike from getting
wrecked

The winter months in my garage
may make my battery lose its charge
yet should the handlebar switches
corrode
I'll never lose faith in my zener
diode

Keep my harness well insulated
the price of a new one has triple
inflated
copper in England is scarce I am
told
so I figure the wires are made
from pure gold

My ammeter's accurate and that's
what I like
it tells me exactly the pitch of
my bike
Uncle Joseph I'll never take your
name in vain
until my magneto breaks down in
the rain . . . again.

Art Sirota

cycle sports
NORTHERN CALIFORNIA'S
Leading Norton Dealer
IN & ON NORTONS SINCE 1970

SALES • PARTS • EXPERT SERVICE



**NOW CLOSING OUT
DUNSTALL ODDS & ENDS
35% TO 50% off**

2355 EL CAMINO REAL
AT SAN TOMAS EXPRESSWAY
SANTA CLARA, CALIFORNIA
(408) 247-1313

Brooks Cyclery

TRIUMPH NORTON BSA	NEW AND USED PARTS TELEPHONE 295-4341 (408)	MOTO-GUZZI DUCATI
ED BROOKS OWNER		1615 ALMADEN ROAD SAN JOSE, CA. 95125

BROOKS CYCLERY HAS BEEN A NORTON DEALER EVER SINCE 1948 AND IS STILL SERVING THE BAY AREA WITH A COMPLETE STOCK OF NEW NORTON PARTS, TOOLS AND ACCESSORIES FOR YOUR NORTON.

- * ED BROOKS - OWNER - 31 YEARS
- * BOB RABER - PARTS - 20 YEARS
- * BILL MANKINS - SERVICE - 12 YEARS

IN ADDITION TO ALL THE OTHER GOODIES IN STOCK, BROOKS IS NOW OFFERING LOCALLY MADE MUFFLERS, HEADER PIPES AND 2 INTO 1 CONVERSIONS FOR ALL COMANDO MODELS. THESE MUFFLERS ARE ACTUALLY BETTER THAN THE STOCK 750 TYPE AND LOOK VERY SIMILAR. CURRENT PRICE IS 20% BELOW STOCK.

MR. BROOKS HAS RECENTLY JOINED THE NORTON OWNERS CLUB, AND WELCOMES ALL MEMBERS AT HIS SHOP FOR A CUP OF COFFEE AND SOME GOOD NORTON TALK. STOP BY AND GIVE HIM SOME OF YOUR BUSINESS, OR JUST STOP BY TO TALK AND CHECK OUT THE BEAUTIFUL OLD MOTORCYCLES HE HAS ON THE SHOWROOM FLOOR. IT'S WORTH IT.

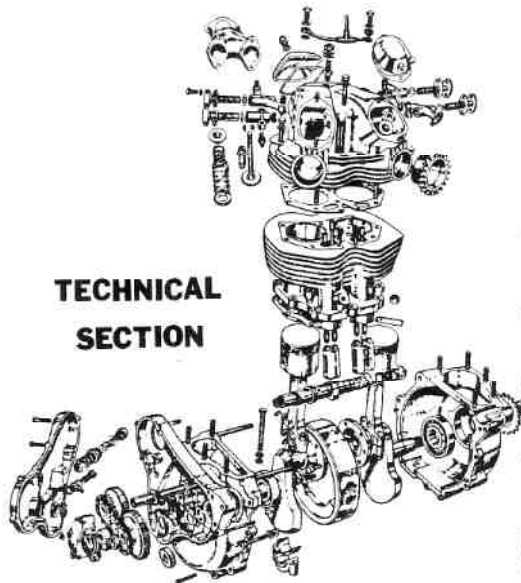

TECHNICAL SECTION

From "The Norton Owners Notebook:

It may be trite to state that the material things we own are taken for granted. It is true that we give little thought to the complexities involved in an industrialized process, or the seemingly impossible problems overcome by the early pioneers of engineering and mechanics. Perhaps here lies the reason that many of today's nihilists and anti-materialists wish to force a return to the stone ages. The lack of appreciation of the work (art?) and genius of a Watt and Boulton seems to cause hatred for any process which enriches mankind in his constant 'upward reach'. I appreciate and enjoy those mechanical things with which I surround myself, whether it is a Norton motorcycle, or the feel of a Snap-on wrench. One of the reasons for this appreciation is a smattering of knowledge of those early craftsmen whose efforts are little known to most of us.

The name Whitworth is surrounded by mystery amongst even the loyal British motorcyclists. "Whitworth? Wentworth? Oh, you mean those bastard-sized wrenches, nuts and bolts on old British bikes. Like those metric nuts and bolts on a H---a?" I think it would behoove the reader to step back to the early 1800's to meet Sir Joseph Whitworth.

Joseph Whitworth (20 December, 1803-22 January, 1887) was the son of a schoolmaster and thus came into life with some advantages, although his parents were not wealthy. At age 14 his father sent him to work in his uncle's cotton mill, and it was here that Whitworth became acquainted with machinery, crude as it was, and soon mastered the operation of the mill.

After four years he became restless, and probably frustrated with the routine of the cotton mill. Whitworth decided to strike out on his own and took a job in Manchester as a working mechanic. After four years at the bench in Manchester, he had saved enough to get married and to move to the center of the best workshop practice: London

London offered the best training in mechanical engineering, and it was here, during the next eight years, that he was employed by the two most famous machine works of the day: Maudslays, and Clements. Maudslay had invented the first screw cutting lathe, as well as many improvements to basic lathe construction, and Clement invented a planing machine. (It is interesting to note here, that in the early 1800's a lathe was essentially a massive wooden sawhorse, with a rotating head at one end which held the workpiece while the operator used a hand-held tool and rest to cut the metal. The accuracy depended entirely on the skill of the machinist, and the results were crude compared to standards thirty years later. Before the invention of the planing machine, a surface was ground, filed by hand, and scraped. Again, as with the early lathes, these methods lacked the precision of today and did little to benefit the progress of mankind. Whitworth's invention of a double acting planing machine which reversed the tool at the end of each stroke, thus cutting in each direction, allowed him to state before the Institution of Mechanical Engineers in 1856: "Thirty years ago the cost of labour for facing a surface of cast iron, by chipping and filing by hand, was twelve shillings per square foot; the same work is now done by the planing machine at a cost for labour of less than one penny per square foot, and this, as you know, is one of the most important operations in mechanics."

Whitworth soon displayed his engineering genius and is credited with the invention of the first true surface plate, or true plane. Accurate machine work depends upon two basic elements: the production of true surfaces and true cylinders. Although perfection of these two operations is an ideal, it will easily be seen that the end result of any complex machining operation will depend on how close to perfection are the round or flat surfaces.

Until Whitworth's discovery, each shop used its own master plate which was planed, ground or filed. Accuracy depended on the machinist, and other plates were produced in the same manner and lapped to match the master plate. This method allowed considerable error, as the master could be convex or concave. It was Whitworth's idea that he should make three plates, and if each of them were true, any one would lift the other.

His workmate commented that, "tha knows nowt about it", but Whitworth persisted and worked at home on the project. After much labor spent scraping and lapping he called his skeptical friend to his home where he exhibited his invention, and John, his workmate, exclaimed, "Ay, tha's done it." This was a great leap for mechanical engineering and was typical of the clear thinking genius which he displayed throughout his life. Once having come upon a problem, he analyzed it and applied sound methods and principles every step of the way until the problem was solved.

The application of true surfaces was demonstrated in every phase of engineering, and in 1840 Whitworth read his paper on "Plane Metallic Surfaces" to the British Association. He stated, in part: "When it is considered that the lathe and the planing engine are used in the making of all other machines and are continually reproducing surfaces similar to their own, it will manifestly appear of the first importance that they should themselves be perfect models.

"A true surface, instead of being in common usage, is almost unknown . . . the want of it in various departments of the arts and manufactures is already sensible . . . printing presses, stereotype plates, slides of all kinds, require a degree of truth much superior to that they generally possess."

By 1833, at the age of 30, he had set up his own shop in Manchester and hung a sign from the one rented room (with steam power available) which read: "Joseph Whitworth, Tool Maker, From London". By 1844 he was employing 200 men, supplying the industry with machine tools of the highest standards. Whitworth always set a goal of mechanical perfection which astounded his contemporaries, and his next step was to introduce a system of exact measurement.

"There is unsurmountable difficulty in converting line measure to end measure . . . line measure depends on sight . . . but the accuracy of end measure is due to the sense of touch."

A good machinist did well to turn a shaft "right to the one-thirty second of an inch" aided by a rule, a caliper laid on the rule, and the eyes, sometimes helped with a magnifying lens. There was another serious difficulty which plagued all the mechanical arts: amazing as it may seem, there was no standard inch! Although the British government had adopted a standard yard, there was no accurate division into feet and inches, and thus each workshop was an island in a sea of confusion. One can well imagine the production of pistons for a Norton motorcycle under these circumstances. Whitworth proceeded to build a measuring machine, based on the application of the true plane, which was a bench model (and forerunner) of our modern micrometer.

His first machines would measure .001", but he later built machines which would measure the difference of one-millionth of an inch. This machine, along with others of his design, were displayed at the Great Exhibition of 1851 at the Crystal Palace and indisputably put Whitworth forth as the first mechanical engineer of the age.

By use of his measuring machines he was able to compare the length of the standard yard, and by an ingenious system of trial and error, to accurately divide the yard into feet and then inches. Due to his pains, the standardization of measurement throughout the industry was accomplished. Soon most of the workshops had measuring machines which allowed use of standard units of measure.

In addition to the development of standard end measure, Whitworth developed and perfected standard gauges for internal and external measure of cylinders. Today these are commonly called go-no-go gauges and are used for determining limits and tolerances of cylindrical parts. Before Whitworth's time, the wheels for rail cars were individually fitted to an axle, allowing no interchangeability. Today the production process of standard sized parts is greatly simplified and much less time-consuming and less costly due to Whitworth's labors. It was not until 1880 that the British Board of Trade finally realized the importance of standardization and adopted his standard gauges. Along with the need for uniformity in the manufacture of component parts, he pushed for the use of the decimal form of measure, that is, in thousandths of an inch instead of fractions, enabling obvious advantages. Whitworth even advocated the use of limitation of sizes to 'proper graduations'. Commenting on candles, he stated: "Candles and candlesticks are used in almost every house, and nothing could be more convenient than for the candle to fit accurately into the sockets of the candlestick, which at present they seldom, or never do . . . in one large Candle Manufacturer, I find eleven sizes of candles . . . each of these sizes being of uncertain diameter, and none of them bearing any definite relation to the size of the Candlesticks."

We see the results of this concept in the various sizes of engine displacement, the 250, 350, 500, 650, 750 cc etc. being used by almost all manufacturers as standards.

In 1841 before the Institution of Civil Engineers, Whitworth read his famous paper: "An Uniform System of Screw Threads". At the time he began his career, there was complete chaos and lack of any standard screw threads or thread forms. Each workshop had its own taps and dies, if indeed they even had these. In many cases each screw was individually mated with a corresponding nut.

There were no rules governing the pitch, depth, form, or strength of the thread; all essential characteristics. Some workshops used 'V' threads, some used rounded threads, and some used square threads. No two were exactly alike. Whitworth perceived the great production and economic advantages of uniform screw threads. The accomplishment of this goal was no simple task and was an arbitrary compromise of all existant forms, taking into account sound engineering principles. Whitworth gathered information from all the well-known workshops in England and formulated a system of standard threads for screws using the 55 degree form. Although Maudslay had previously tried to have an universal screw thread system introduced, it was Whitworth's dogged persistence and promotion of what he knew to be right that allowed him to claim by 1858 that his standards had been adopted. Time and use have shown that his system provides a strong and durable screw, less prone to damage from physical abuses and more resistant to fractures dues to the rounded profile.

Sir Joseph Whitworth was a man of many interests, a man of method and orderliness. Amongst his many endeavors there are several, aside from those already metnioned, which, I think, bear comment. One of his prime considerations in the production of any mechanism was to build it simply with the least number of moving parts and the smallest mass necessary for strength. "It should be an axiom in mechanics that whatever has motion should be as light as circumstances will admit."

(It is of interest to remember this when examining the construction of the Norton motorcycle, as compared to some others.) Up to about the middle of the nineteenth century, the production of steel was limited to small cast ingots of about 75 lbs, which were forged for use in springs, cutlery, precision machine parts, and the like. Large parts, such as crankshafts for steam engines, axles, wheels, and general structural parts were of cast iron. The use of cast iron necessitated a large mass for strength, which complicated production of any large machine. Thus, he devised a process whereby "iron of great strength free from seams, flaws, and hard places" could be easily produced in large ingots. Known as 'fluid-pressed steel', his patented process used hydraulic pressure of six tons per square inch to force a ram down upon molten steel in a special mould of his own design, thus eliminating impurities, gasses, and internal stresses. The resultant casting, when cooled, was found to be sound and could be forged into various parts which were not possible before. Although this process is not in use today, it was a significant advance at the time, for the production of large axles, crankshafts, etc. were facilitated with stronger and lighter materials.

In 1854, because of Whitworth's renown as the greatest engineer of his time, the Board of Ordnance asked that he conduct experiments on the development of a more accurate shoulder arm than the Enfield rifle musket. England was then involved in the Crimean War and was faced with problems of production and performance of the Enfield weapons. Knowing little of weaponry but resolved to overcome the proposed problems, he set about the business with his characteristic orderliness. Having toured the Enfield Royal Small Arms factories, he reached several conclusions: that high quality steel was far superior to iron for rifle barrels and that the current rifling designs were all wrong from an engineering standpoint. The vast differences of opinion of various rifle makers convinced him that he must carry out his own independent tests to determine the best principles of rifling and ballistic design. Realizing that accuracy and range were dependent upon the form of rifling, the shape and weight of the bullet (sectional density), he found that polygonally shaped rifling and matched projectile gave the best results. The projectile had maximum bearing support on all sides as it was guided along the bore, and this he considered mechanically perfect. The rate of twist of the rifling was also determined by careful experimentation and formulas set forth for all the variables which would allow the best results with any bore diameter.

The rifle requested by the government was submitted and proven beyond the slightest doubt to be far superior to anything available at the time, especially at ranges exceeding 1500 yards. However, due to the 'traditional ideas' of the Ordnance Board, the weapon was not adopted by the British military. He was very bitter about this injustice done him by the government, being "a man of strong, unbending will . . . he would not modify a model which he knew to be right, out of deference to committees who he considered were incomparably his inferiors in technical knowledge" regarding "official and infallible as far from synonymous."

CONT. NEXT MONTH

"THE NORTON OWNERS NOTEBOOK" and the above text are registered to the author, Leonidas M. Schwartz, Keswick, Virginia. Permission must be obtained in writing to reprint or use any part thereof.



TRADING POST

Current and prospective members may place Norton-related ads in the TRADING POST by writing the pertinent information in as concise a form as possible and sending it to the Editor. Ads will normally run for two months, but they may be renewed should the advertiser so desire. There will be no fee for any advertisement in the TRADING POST.

Commercial enterprises may advertise their goods and/or services in the NORTON NOTICE for a nominal fee which will help offset printing costs and thereby support the Northern California Branch of the NOC.

Commercial advertising rates are:

	1 issue	3 issues	6 issues
1/4 page	\$10	\$25	\$45
1/2 page	\$15	\$40	\$70

Wanted: John Player Norton in very good/excellent condition. Will pay cash only.

Wanted: Interstate tank/seat combo for '72/'73 750.

Wanted: Fastback tailpiece/LH side-cover/fork ears

DAVE HOFFMAN (916) 725-8727
7439 Apache Way
Citrus Heights, California 95610

1974 850 Commando parts for sale. Reasonable prices. Engine parts, seat, turn signals, etc. Call Greg or Mike (408) 866-0912

1975 Norton 850 Commando (not a Mark III). White with red and blue trim, 4000 original miles, immaculate condition, original owner. Asking \$1,700 and will consider trades. I would also appreciate any leads on a Vincent Black Shadow.

ANDY ZITELLI
(415) 327-8777

For Sale-Front hub, caliper, and master cylinder for 1975 Norton. \$100.

Engine, Triumph 500 cc. twin. \$125.

WAYNE SEEBERG
(415)229-0414

1972 Norton Commando with Interstate Tank. Good condition. Call Richard at 564-9293 Home
955-8320 Work

For Sale: 1973 Norton Commando, 750cc. Bike is in excellent condition both looks and running. Comes with extras including complete workshop manual. \$1,300.00. Call Pete Mayer (408) 207-7947 early morn
(408) 998-0568 anytime

Wanted-1975 Commando Mk III Mufflers
Have Wassels and Cash

DENNIS POWELL
(415)534-1970 Wk
(415)636-1798 Res

Late 72 Dunstall Norton 810, fresh barrels, pistons, rings. Balanced, all threads helicoiled and chamfered.

Quaife 5 speed with webbed case, Borrani's, TT100's, Twin disc (Dunstall) front end, Dunstall Mark II Head (PM Custom guides, PC Seals, Sifton (S&W) Springs, retainers... Ported, etc.) All parts new. Fresh valve job. Mercury outboard coils.

Dunstall 2-1-2 exhaust, Interstate glass tank, glass fender, all midnite blue, Cibie Lamp.

2500 original miles, meticulously maintained and cared for. Tach/Speedo calibrated by Nisonger/LAX.

All original correspondence/tests/etc. with Paul Dunstall, all receipts.

Best offer.

David L. Severini
(415)692-1332 Days



NEW HOSS CYCLE PARTS AND SERVICE

Steve Murray, co-owner of New Hoss Cycle, is an associate member of the Northern California Branch. If you're looking for "the long deal" on TIRES, TUBES, BATTERY, etc. for your Norton or Japanese bike he is the man to call. He really wants your business, and will give you a good deal.

Unfortunately, New Hoss does not service English bikes. (Yet?) However Steve hopes all you Norton fans with a Japanese bike will stop by and chat sometime. If he can do anything for you let him know.

NEW HOSS CYCLE PARTS AND SERVICE

1001 MARK ST.
CORNER OF REDFIELD
REDWOOD CITY, CA
366-1330

ALAN DONNEY
STEVE MURRAY



- motorcycle sales
- self service
- accessory dept
- complete service dept.
- machine shop
- insurance
- notary service

See Jack Morris, a branch member and Norton enthusiast for quite a few years, if you're looking for parts or accessories. Jack's got the goodies and will take the time to make sure you get exactly what you need.

Selby's service department is in the able hands of Alan Hook, an experienced Norton mechanic and also a branch member. If the Nort isn't running right and you're unsure about what to do, take it to Alan and he'll see that it gets back into tip-top shape.

346 El Camino Real
Redwood City, Ca. 94062

(415) 369-4112



T. T. Motors

2800 Adeline • Berkeley, CA 94703
(415) 845-8235

NORTON ENTHUSIASTS: We specialize in Early and Late Commando Parts, and we offer a complete Service and Machine shop for your Norton work.

STOP BY AND VISIT - CHECK THESE ITEMS OUT!

- * COMPLETE LINE OF BRITISH TOOLS
- * NEW BLACK ROADSTER TANKS
- * FACTORY WORKSHOP MANUALS: MKII & MKIII
- * COMPLETE GEARBOXES, CASES AND GEARS

*SPEED EQUIPMENT:

- MEGACYCLE AND NORRIS CAMSHAFTS
- PM RACING VALVE SPRINGS AND GUIDES
- BRANCH RACING VALVES
- SINGLE MIKUNI KITS

*SERVICE DEPARTMENT BUILDING AND MODIFICATION OF STREET AND RACING MACHINES:

- EXHAUST PORT REPAIR
- VALVE JOBS
- CYLINDER BORING
- HEAD MILLING AND SURFACING
- MAGNAFLUX
- AND MUCH, MUCH MORE!!!

*FINALLY WE OFFER A 10% DISCOUNT ON ALL NORTON PARTS TO MEMBERS OF THE NORTON OWNERS CLUB
(Service work is not included)

MOTORCYCLES UNLIMITED

Sales and Service

(415) 924-0927
ALEX S. McLEAN 9776 PANADISE DRIVE
OWNER CORTE MADERA, CA. 94028

Motorcycles Unlimited is the West Coast distributor for Dunstall.

Complete stocklists for:

Dunstall

Rear Sets	Valve Springs
Silencers	2-1-2 Center Stand
Gas Tanks	Clip-ons
Cylinder Heads	Oil Feed Line
Front Fenders	G.T. Fairing
	Replacement
	Windshields

Plus a full supply of stock Norton bits.

Classic Nortons on display.

LARRY RANDALL

English Specialist

West Bay Cycle Dismantlers, Inc.

ENGINE REBUILDING & MACHINING FACILITIES
USED PARTS & ACCESSORIES
USED MOTORCYCLES

750 San Antonio Road
Palo Alto, California 94303

(415) 494-8033

10% DISCOUNT TO NOC MEMBERS ON ALL NEW AND USED PARTS. A DEAL!

Larry Randall and Jan Barton are good people to know. At WEST BAY they have many used Norton parts at reasonable prices, as well as the expertise to help you solve any tricky problems that come up the next time you try to do some repair job. They are definitely the first people to call if you live on the peninsula and don't have the part you need, or the foggiest idea how to put the old Nort back together again.